

PROJECT	QUANTITY	ITEM NO
---------	----------	---------

Bun Warmer

BW 4 4 trays x 2 shelves



BW 4 bun warmer with 2 shelves, 4 trays across

Henny Penny Bun warmers help maintain higher bun quality and texture while improving the efficiency of sandwich production.

The BW 4 is a compact, low profile countertop cabinet designed to keep buns at optimal temperature and texture while offering efficient access across workflow.

Two shelves hold 4 trays each. Gentle convection heating is circulated through an air duct system to heat the entire cabinet evenly, so all buns achieve consistent quality.

Access is fast and easy with scratch resistant acrylic sliding glass doors, or optional flip up doors.

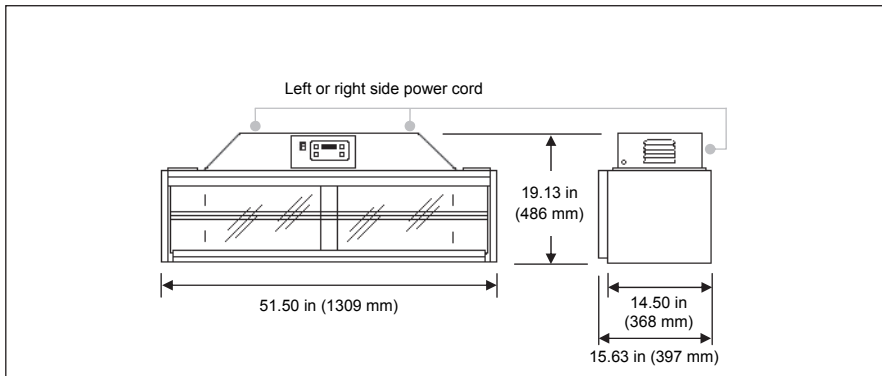

Standard Features

- Stainless steel construction for easy-cleaning and long life
- Electronic temperature control with program lock and digital clock
- 2 wire tray shelves accept standard bun trays, 4 per shelf
- Top mounted control housing saves counter space
- 2 scratch-resistant acrylic doors, sliding or flip-up (optional)
- Convection blower with enhanced air duct system warms interior evenly

Dimensions

Height	19.13 in (486 mm)
Width	51.50 in (1309 mm)
Depth	14.50 in (368 mm) at base 15.63 in (397 mm) overall

Crated

Length	55 in (1400 mm)
Depth	22 in (550 mm)
Height	27 in (690 mm)
Volume	19 ft ³ (0.53 m ³)
Weight	149 lb (68 kg)

Heating

Electric convection
Thermostat 140°–200°F (60°–93°C)

Tray capacity

8 standard bun trays 10.50 x 14.00 in (267 x 356 mm) on 2 shelves, 4 per shelf

Required clearances N/A

Electrical

Volts	Phase	Hertz	kW	Amps	Wire
120	1	50/60	1.09	9.1	2+G
220	1	50/60	0.50	2.3	2+G
230	1	50	0.55	2.4	1NG

Laboratory certifications



Please specify desired configuration Style

Pass-through Solid back

Doors

Sliding Flip-up (optional)

Power cord

Left side Right side

Bidding specifications

Provide Henny Penny bun warmer model BW 4 for maintaining high quality buns and more efficient sandwich production.

Unit shall incorporate:

- 2 stainless steel wire shelves
- 2 Sliding doors of scratch-resistant acrylic (flip-up doors optional)
- High-quality stainless steel construction
- Electric convection heating
- Electronic temperature controls

Continuing product improvement may subject specifications to change without notice.

<input type="checkbox"/> APPROVED	<input type="checkbox"/> APPROVED AS NOTED	<input type="checkbox"/> RESUBMIT
AUTHORIZED SIGNATURE		DATE

Henny Penny Corporation
PO Box 60 Eaton OH 45320 USA

+1 937.456.8400 800.417.8417
+1 937.456.8434 Fax 800.417.8434 Fax
+1.800.417.8405 Technical Support

www.hennypenny.com

HENNY PENNY
Engineered to Last