

PROJECT	QUANTITY	ITEM NO
---------	----------	---------

# Bun Warmer

**BW 6** 6 trays x 3 shelves



BW 6 bun warmer with 3 shelves, 6 trays across

Henny Penny Bun warmers help maintain higher bun quality and texture while improving the efficiency of sandwich production.

The BW 6 is a high capacity, low profile countertop cabinet designed to keep a maximum number of buns at optimal temperature and texture while offering efficient access across workflow.

Three shelves hold 6 trays each. Gentle convection heating is circulated through an air duct system to heat the entire cabinet evenly, so all buns achieve consistent quality.

Access is fast and easy with scratch resistant acrylic sliding glass doors.

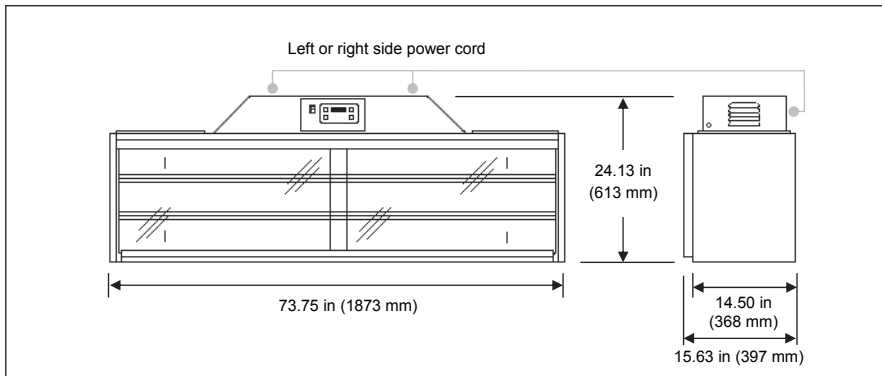

### Standard Features

- Stainless steel construction for easy-cleaning and long life
- Electronic temperature control with program lock and digital clock
- 3 wire tray shelves accept standard bun trays, 6 per shelf
- Top mounted control housing saves counter space
- 2 scratch-resistant acrylic sliding doors
- Convection blower with enhanced air duct system warms interior evenly

### Please specify desired configuration

Power cord

- Left side  Right side

### Dimensions

Height	24.13 in (613 mm)
Width	73.75 in (1873 mm)
Depth	14.50 in (368 mm) at base
	15.63 in (397 mm) overall

### Heating

Electric convection  
Thermostat 140°–200°F (60°–93°C)

### Tray capacity

18 standard bun trays 10.50 x 14.00 in (267 x 356 mm) on 3 shelves, 6 per shelf

### Crated

Length	77 in (1955 mm)
Depth	22 in (560 mm)
Height	32 in (815 mm)
Volume	31 ft <sup>3</sup> (0.88 m <sup>3</sup> )
Weight	229 lb (104 kg)

Required clearances N/A

### Electrical

Volts	Phase	Hertz	kW	Amps	Wire
120	1	50/60	1.64	13.7	2+G
240	1	50/60	1.80	7.5	2+G
230	1	50	1.60	7.0	1NG

### Laboratory certifications



### Bidding specifications

Provide Henny Penny BW 6 Bun Warmer for maintaining high quality buns and more efficient sandwich production.

Unit shall incorporate:

- 3 stainless steel wire shelves
- Sliding door of scratch-resistant acrylic
- High-quality stainless steel construction
- Electric convection heating
- Electronic temperature controls

Continuing product improvement may subject specifications to change without notice.

<input type="checkbox"/> APPROVED	<input type="checkbox"/> APPROVED AS NOTED	<input type="checkbox"/> RESUBMIT
AUTHORIZED SIGNATURE		DATE

Henny Penny Corporation  
PO Box 60 Eaton OH 45320 USA

+1 937.456.8400 800.417.8417  
+1 937.456.8434 Fax 800.417.8434 Fax  
+1.800.417.8405 Technical Support

[www.hennypenny.com](http://www.hennypenny.com)

**HENNY PENNY**  
Engineered to Last