

# Il Carrettino CARAPINE



Gelato trolley with ventilated refrigeration, finned evaporator and automatic hot gas defrosting. One piece body with ecological polyurethane insulation (HCFC & HFC free), foamed with CO<sub>2</sub>. Internal tank and service top in stainless steel. External tank in carbon steel with serigraphies. External base in painted sheet. Tempered glass structure. Curved straight front glass. Sun curtain with side supports in tubular stainless steel. Built-in hermetic condensing unit with electronic control board. Main structure in carbon steel painted with powder, 2 ray wheels and one pivoting wheel. Handle in tubular stainless steel for an easier handling.

Carrettino dei gelati a refrigerazione ventilata con evaporatore alettato e sbrinamento automatico a gas caldo. Scocca monolitica coibentata con poliuretano ecologico (HCFC & HFC free) espanso a CO<sub>2</sub>. Interno vasca e piano di servizio in acciaio inox. Esterno vasca in acciaio al carbonio verniciato a polvere epossidica con serigrafia decorativa su tutto il perimetro. Esterno fondo vasca in lamiera prevemiciata. Sovrastruttura in cristallo temperato, con vetro frontale dritto. Tenda decorativa parasole con sostegni laterali in acciaio al carbonio. Unità condensatrice ermetica a bordo con quadro comandi elettronico. Struttura in acciaio al carbonio verniciato a polvere, con 2 ruote a raggi e ruotino pivottante. Maniglia in acciaio inox tubolare per facilitare la movimentazione.



**INSTALLATION**  
Plug-in



**TEMPERATURE**  
-16/-14 °C



**DEFROST**  
Hot gas



**CLIMATIC CLASS**  
4

## Standard equipment

Scoop washer

Water tap

Tanks

Carapine lids

## Dotazioni di serie

Lavaporzionatore

Rubinetto

Taniche

Coperchi per carapine



## Il Carrettino CARAPINE **Catalog - Catalogo**

Model Modello	Code Codice	Code Codice	Condensing unit included Unità condensatrice a bordo	Containers arrangement Allestimento carapine
	<b>R404A</b>	<b>R290</b>	<b>R404A / R290</b> <b>Air</b> Aria	 <b>7 Lt</b> 200 x 250h 9002140011000 ***** each/cad.
<b>RV</b>	<b>Yellow</b>	9001115506005	9001115506015	<b>8</b>
	<b>Brown</b>	9001115506003	9001115506017	
	<b>White</b>	9001115506008	9001115506014	
	<b>Black</b>	9001115506009	9001115506016	

## Il Carrettino CARAPINE **Technical features - Caratteristiche tecniche**

	<b>Carapine</b>	
<b>External dimensions (LxDxH)</b> Dimensioni esterne (LxPxH)	2000 X 1285 X 2081 mm	
<b>Capacity (gross/net)</b> Capacità (lorda/netta)	260 / 104 lt	
<b>Net weight</b> Peso netto	205 kg	
<b>Refrigeration</b> Refrigerazione	Ventilated - Ventilated	
<b>Refrigerant</b> Refrigerante	R404A [1] - R290 [2]	
<b>Climatic class</b> Classe climatica	4	
<b>Operating conditions</b> Condizioni ambientali	30 °C / 55 %RH	
<b>Product temperature</b> Temperatura prodotto	-16/-14 °C	
<b>Compressor (q.ty-type)</b> Compressore (q.tà-tipologia)	1 Hermetic - 1 Ermetico	
<b>Defrost</b> Sbrinamento	Hot gas - Gas caldo	
<b>Power supply</b> Alimentazione	230 V / 1 Ph / 50 Hz	
<b>Electrical input (standard)</b> Assorbimento elettrico [standard]	[1] 500 W / 2,8 A	[2] 590 W / 2,8 A
<b>Electrical input (defrost)</b> Assorbimento elettrico (sbrinamento)	[1] 1200 W / 5,9 A	[2] 660 W / 3,1 A

### Section - Sezioni

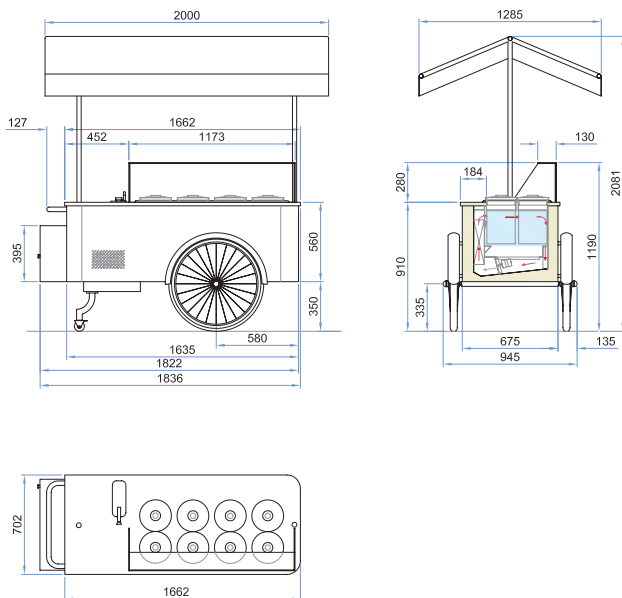

### Available Colours - Colori disponibili

