

# Indigo™ Series 500 Ice Cube Machine

Model:  ID-0502A  IY-0504A  ID-0503W  IY-0505W  ID-0592N  IY-0594N



Indigo Series i-500 Ice Machine on B-570 Bin

Designed for operators who know that ice is critical to their business, the Indigo™ Series ice machine's preventative diagnostics continually monitor itself for reliable ice production. Improvements in cleanability and programmability make your ice machine easy to own and less expensive to operate.

- **Space-Saving Design** – Up to 560 lbs. (254 kgs.) daily ice production and only 30" (76.20 cm) wide.
- **Intelligent Diagnostics** – provide 24 hour preventative maintenance and diagnostic feedback for trouble free operation.
- **Acoustical Ice Sensing Probe** – for reliable operation in challenging water conditions.
- **EasyRead Display** – communicates operating status, cleaning reminders, and asset information through a blue illuminated display.
- **Programmable Ice Production** – by On/Off Time, Ice Volume or Bin Level (with accessory bin level control) further improves energy efficiency and savings.
- **Easy to Clean Foodzone** – Hinged front door swings out for easy access. Removable water-trough, distribution tube, curtain, and sensing probes for fast and efficient cleaning. Select components made with AlphaSan® antimicrobial.
- **DuraTech™ Exterior** – provides superior corrosion resistance. Stainless finish with innovative clear-coat resists fingerprints and dirt.
- Available **LuminIce™ Growth Inhibitor** controls the growth of bacteria and yeast within the foodzone.

## Ice Machine Electric

115/60/1 standard.  
(208-230/60/1 and 230/50/1 also available)

|                                  |                           |
|----------------------------------|---------------------------|
| <b>Minimum circuit ampacity:</b> | <b>Maximum fuse size:</b> |
| Air cooled: 14.2                 | Air Cooled: 20.0          |
| Water Cooled: 13.5               | Water Cooled: 20.0        |
| Remote: 20.0                     | Remote: 25.0              |

## Specifications

**BTU Per Hour:**  
6,100 (average) 6,900 (peak)

**Refrigerant:**  
R-404A CFC-free

### Operating Limits:

- Ambient Temperature Range: 35° to 110°F (1.7° to 43.3°C)  
Water Temperature Range: 35° to 90°F (1.7° to 32.2°C)
- Water Pressure Ice Maker  
Water In:  
Min. 20 psi (137.9 kPa)  
Max. 80 psi (551.1 kPa)



## Ice Shape

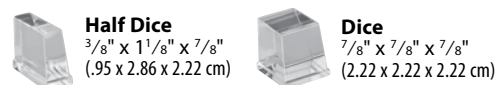



# Indigo™ Series 500 Ice Cube Machine

## i-500 on B-570 Storage Bin

- (A) Electrical Entrance (2) Options
- (B) 3/8" (0.95 cm) F.P.T. Water Condenser Inlet (water-cooled units)
- (C) 1/2" (1.27 cm) F.P.T. Water Condenser Outlet (water-cooled units)
- (D) 1/2" (1.27 cm) Auxillary Base Drain Socket
- (E) 3/8" (0.95 cm) F.P.T. Ice Making Water Inlet
- (F) 1/2" (1.27 cm) F.P.T. Ice Making Water Drain
- (G) 3/4" (1.91 cm) Bin Drain

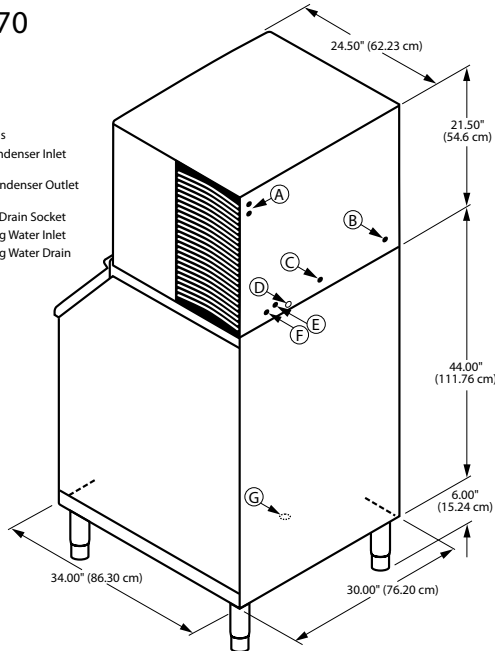

**Installation Note**  
Minimum installation clearance:  
Top/sides: 8" (20.32 cm);  
Back is 5" (12.7 cm)

## Space-Saving Designs



|             | <b>i-500 B-400</b>      | <b>i-500 B-570</b>      |
|-------------|-------------------------|-------------------------|
| Height      | 59.50"<br>151.13 cm     | 71.50"<br>181.61 cm     |
| Width       | 30.00"<br>76.20 cm      | 30.00"<br>76.20 cm      |
| Depth       | 34.00"<br>86.30 cm      | 34.00"<br>86.30 cm      |
| Bin Storage | 290 lbs.<br>131.54 kgs. | 430 lbs.<br>195.04 kgs. |

Height includes adjustable bin legs 6.00" to 8.00", (15.24 to 20.32 cm) set at 6.00" (15.24 cm).

## Specifications

|   | Model    | Ice Shape | Ice Production 24 Hours |                    | Power Usage kWh/100 lbs. @90°Air/70°F | Water Usage/ 100 lbs. 45.4 kgs. of Ice | ENERGY STAR* |
|---|----------|-----------|-------------------------|--------------------|---------------------------------------|--|--------------|
|   |          |           | 70°Air/ 50°F Water      | 90°Air/ 70°F Water |                                       |  |              |
| <b>AIR-COOLED</b>   | ID-0502A | dice      | 530 lbs.                | 390 lbs.           | 5.79                                  | 19.9 Gal.                              | ★            |
|   |          |           | 240 kgs.                | 177 kgs.           |                                       | 75.3 L                                 |              |
| <b>AIR-COOLED</b>   | IY-0504A | half-dice | 560 lbs.                | 410 lbs.           | 5.73                                  | 19.9 Gal.                              | ★            |
|   |          |           | 254 kgs.                | 186 kgs.           |                                       | 75.3 L                                 |              |
| <b>WATER-COOLED</b>   | ID-0503W | dice      | 550 lbs.                | 430 lbs.           | 4.58                                  | 19.9 Gal.                              | NA           |
|   |          |           | 249 kgs.                | 195 kgs.           |                                       | 75.3 L                                 |              |
| <b>WATER-COOLED</b>   | IY-0505W | half-dice | 550 lbs.                | 440 lbs.           | 4.52                                  | 19.9 Gal.                              | NA           |
|   |          |           | 249 kgs.                | 200 kgs.           |                                       | 75.3 L                                 |              |
| * Water-cooled Condenser Water Usage / 100 lbs. /45.4 kgs. Of Ice: 165 gal/625 L. |          |           |                         |                    |                                       |  |              |
| * Water-cooled models are excluded from ENERGY STAR qualification.                |          |           |                         |                    |                                       |  |              |
| <b>REMOTE-COOLED</b>  | ID-0592N | dice      | 480 lbs.                | 430 lbs.           | 5.79                                  | 19.9 Gal.                              | ★            |
|   |          |           | 218 kgs.                | 195 kgs.           |                                       | 75.3 L                                 |              |
| <b>REMOTE-COOLED</b>  | IY-0594N | half-dice | 510 lbs.                | 440 lbs.           | 5.73                                  | 19.9 Gal.                              | ★            |
|   |          |           | 231 kgs.                | 200 kgs.           |                                       | 75.3 L                                 |              |

Order ice storage bin separately. Ice storage bin and JC-0495 remote condenser must be ordered separately. Consult remote condenser specification sheet for details.

## Accessories

**LuminIce™ Growth Inhibitor**  
reduces yeast and bacteria growth for a cleaner ice machine.



**Bin Level Control**  
Allows ice bin level to be automatically set. Built-in LED light illuminates bin.



**Arctic Pure® Water Filters**  
Reduces sediment and chlorine odors for better tasting ice.



**AuCS®**  
schedules and performs routine ice machine cleaning automatically.

