

BW4-CTM-RL (CE / UL)

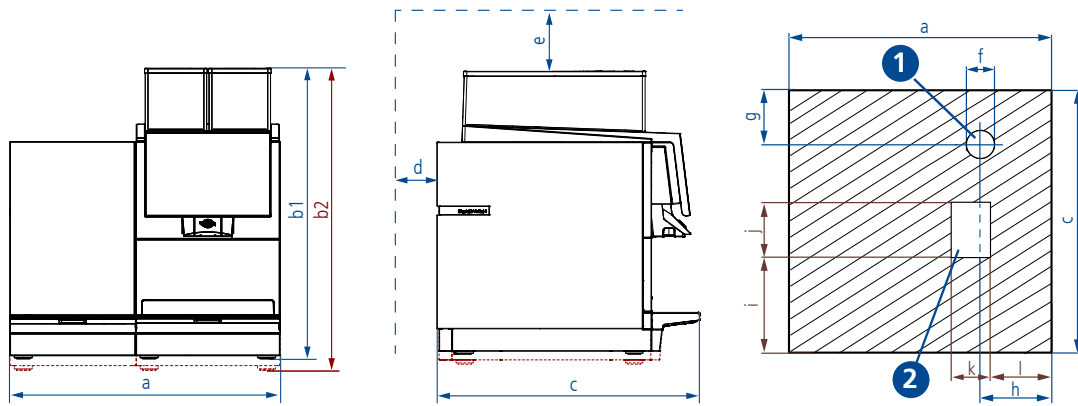

- 1 Hole diameter of 70 mm / 2.75 in for water/milk inlet and water drain. Also possible for power cord.
- 2 Cut-out for grounds ejection

a	600 mm / 23.62 in	c	600 mm / 23.62 in	f	70 mm / 2.75 in	i	213 mm / 8.38 in
b1	CE: 646 mm / 25.43 in (feet: 57 mm / 2.24 in) or optionally 676 mm / 26.61 in (feet: 87 mm / 3.42 in)	d	50 mm / 1.96 in	g	150 mm / 5.9 in	j	106 mm / 4.17 in
b2	UL: 676 mm / 26.61 in (feet: 87 mm / 3.42 in)	e	350 mm / 13.77 in	h	160 mm / 6.29 in	k	63 mm / 2.48 in
						l	146 mm / 5.74 in

Drain

- m: Distance of machine to drain < 1 m / 39.37 in.
- Drain line (hose) not sagging.
- No back pressure in the water line.
- The end of the line not submerged in water.

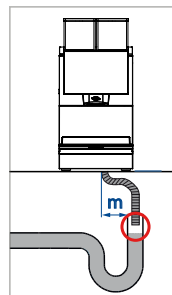

Machine parameters		Water connection specifications		
Connection / power CE	Machine with single phase (limited performance):	220-240 VAC / 50-60 Hz 3100-3700 W / 16 A 220-240 VAC / 50-60 Hz 2700-3100 W / 13 A	Water supply	3/8"
	Machine with single phase:	220-240 VAC / 50-60 Hz 5800-7100 W / 32 A	Dynamic water pressure	2-4 bar 30-60 psi
	Machine with three phases:	380-415 VAC / 50-60 Hz 5800-7100 W / 3 x 16 A	Water boiler pressure	11.7 bar 169.6 psi
Connection / power UL		208 VAC / 60 Hz 5700 W / 27 A	Steam boiler pressure	2.6 bar 37.7 psi
Outlet height	85-172 mm (manual) / 96-192 mm (automatic) 3.34-6.77 in (manual) / 3.77-7.55 in (automatic)		Chlorine	None
Weight	75.73 kg / 166.95 lbs		TDS	70-200 ppm
			Total hardness	5-8 °dH / 8-14 °fH
			pH	6.8-7.4
			Alkalinity	<100 ppm
			Iron	<0.25 ppm