

## 2. Data Sheet Black&White4 compact CTM-RS

Height / Width (Front View)

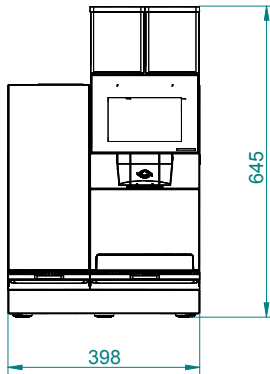

Depth (Side View)

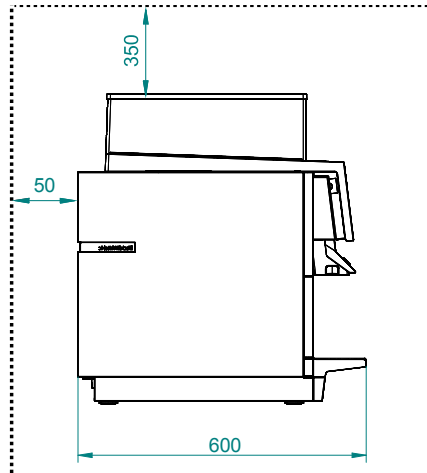

Machine parameters	
<b>Connections</b>	Coffee machine: 220-240 VAC   12 A   50/60 Hz Refrigerator: 220-240 VAC   0.75 A   50/60 Hz
<b>Output</b>	2700-3100 W
<b>Dimensions</b>	398 x 600 x 645 mm (W / D / H)
<b>Coffee spout height standard</b>	85-175 mm
<b>Weight</b>	56 kg

Water connection parameters	
<b>Water connection</b>	3/8"
<b>Water pressure</b>	2-4 bar / 30-60 psi
<b>Chlorine</b>	None
<b>TDS</b>	70-200 ppm
<b>Hardness</b>	5-8 °dH (8-14 °fH)
<b>pH</b>	6.8 bis 7.4
<b>Alkalinity</b>	less than 100 ppm
<b>Iron</b>	less than 0.25 ppm

Conversion table water hardness					
Water hardness	DE	FR	EN	Ppm	Mval/l
1° dH	1.0	1.79	1.25	17.8	0.357
1° fH	0.56	1.0	0.7	10.0	0.2
1° e	0.8	1.43	1.0	14.3	0.86
1° ppm	0.056	0.1	0.07	1.0	0.02
1 mval/l	2.8	5.0	3.5	50.0	1.0

### ⚠ Drainage

- The distance between the drain and the machine **must not be more than 1 m**.
- Make sure there is **no** dip in the drain hose.
- Make sure there is **no** back pressure in the drain hose.
- The end of the hose **must not** be in the water.

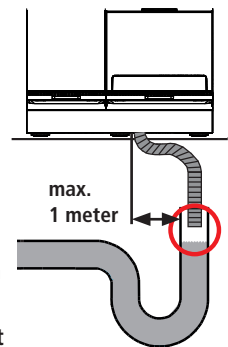

Hole diameter 70mm for water inlet and outlet.  
 Also possible for electric cords.

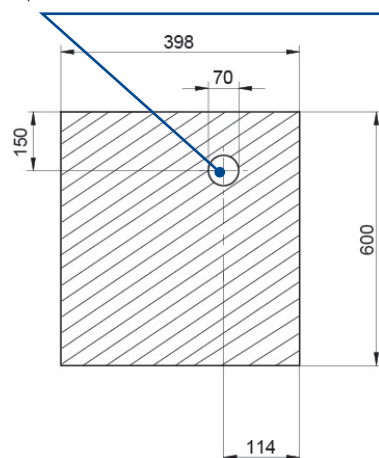

For further details regarding installation check the Technical Manual.