



**TRUE FOOD SERVICE EQUIPMENT, INC.**

2001 East Terra Lane • O'Fallon, Missouri 63366-4434 • (636)240-2400  
 Fax (636)272-2408 • Toll Free (800)325-6152 • Intl Fax# (001)636-272-7546  
 Parts Dept. (800)424-TRUE • Parts Dept. Fax# (636)272-9471 • www.truemfg.com

Project Name: \_\_\_\_\_

Location: \_\_\_\_\_

Item #: \_\_\_\_\_ Qty: \_\_\_\_\_

Model #: \_\_\_\_\_

A/A #

S/S #

Model:  
**TDD-2CT**

**Underbar Refrigeration:**  
*Solid Swing Door Club Top Direct Draw Beer Dispenser*



**TDD-2CT**

- ▶ True's direct draw beer dispensers are designed with enduring quality and value. Our commitment to using the highest quality materials and oversized refrigeration assures colder product temperatures and years of trouble free service.
- ▶ Easy to reach refrigerated storage area under slide top for chilled product or glasses.
- ▶ Oversized, factory balanced, refrigeration system holds 33°F to 38°F (.5°C to 3.3°C).
- ▶ Exterior - heavy duty, wear resistant laminated black vinyl front and sides. Matching black aluminum back. All stainless steel counter top and lid.
- ▶ Interior - Stainless steel floor with ½" (13 mm) reinforced lip and heavy gauge galvanized steel walls.
- ▶ Adjustable, heavy duty PVC coated wire shelf.
- ▶ Two (2) 3" (77 mm) diameter stainless steel insulated beer columns. Cold air is directed into beer columns to reduce foaming and maximize draft beer profits.
- ▶ Anodized aluminum glass rail provides convenient storage for glasses on top.
- ▶ Entire cabinet structure and solid doors are foamed-in-place using Ecomate. A high density, polyurethane insulation that has zero ozone depletion potential (ODP) and zero global warming potential (GWP).

**ROUGH-IN DATA**

Specifications subject to change without notice.  
 Chart dimensions rounded up to the nearest 1/8" (millimeters rounded up to next whole number).

Model	Doors	Capacity ½ Barrels	Shelves	Cabinet Dimensions (inches) (mm)			HP	Voltage	Amps	NEMA Config.	Cord Length (total ft.) (total m)	Crated Weight (lbs.) (kg)
				L	D†	H*						
TDD-2CT	2	2	1	58 7/8	27 1/8	38 1/2	1/3	115/60/1	9.1	5-15P	7	350
				1496	689	978	1/3	230-240/50/1	4.2	▲	2.13	159

† Depth does not include 1" (26 mm) for rear bumpers.  
 \* Height does not include 13 3/4" (350 mm) for draft arms.

▲ Plug type varies by country.

	<p><b>APPROVALS:</b></p>	<p><b>AVAILABLE AT:</b></p>
<p>6/15 Printed in U.S.A.</p>		

Model:  
**TDD-2CT**

# Underbar Refrigeration: Solid Swing Door Club Top Direct Draw Beer Dispenser



## STANDARD FEATURES

### DESIGN

- True's direct draw beer dispensers are designed with enduring quality and value. Our commitment to using the highest quality materials and oversized refrigeration assures colder product temperatures and years of trouble free service.

### REFRIGERATION SYSTEM

- Factory engineered, self-contained, capillary tube system using environmentally friendly (CFC free) 134A refrigerant.
- Extra large evaporator coil balanced with higher horsepower compressor and large condenser; maintains cabinet temperatures of 33°F to 38°F (.5°C to 3.3°C).
- Sealed, cast iron, self-lubricating evaporator fan motor(s) and larger fan blades give True beer dispensers a more efficient low velocity, high volume airflow design. This unique design ensures faster temperature pull down of warm product, colder holding temperatures and faster recovery in high use situations.
- Condensing unit accessed from behind front grill, slides out for easy cleaning and maintenance.

### CABINET CONSTRUCTION

- Exterior - heavy duty, wear resistant laminated black vinyl front and sides. Matching black aluminum back. All stainless steel counter top and lid.
- Interior - Stainless steel floor with 1/2" (13 mm) reinforced lip and heavy gauge galvanized steel walls.

- Door threshold protector prevents damage to cabinet from routine loading of product.
- Insulation - entire cabinet structure and solid doors are foamed-in-place using Ecomate. A high density, polyurethane insulation that has zero ozone depletion potential (ODP) and zero global warming potential (GWP).
- Welded, heavy duty steel frame rail, black powder coated for corrosion protection.
- Two (2) 3" (77 mm) diameter stainless steel insulated beer columns. Cold air is directed into beer column(s) to reduce foaming and maximize draft beer profits.
- Anodized aluminum glass rail.

### DOORS

- Wear-resistant laminated black vinyl exterior with heavy gauge galvanized steel liner.
- Each door fitted with 12" (305 mm) long recessed handle that is foamed-in-place with a sheet metal interlock to ensure permanent attachment.
- Positive seal doors.
- Magnetic door gasket(s) of one piece construction, removable without tools for ease of cleaning.
- Door locks standard.

### SHELVING

- One (1) adjustable, heavy duty, black, PVC coated wire shelves 11 3/8" L x 21 1/4" D (289 mm x 540 mm). Four (4) chrome plated shelf clips included.
- Aluminum shelf support pilasters. Shelf is adjustable on 1/2" (13 mm) increments.

### LIGHTING

- Incandescent interior lighting.

### MODEL FEATURES

- Evaporator is epoxy coated to eliminate the potential of corrosion.
- Convenient 1/2" (13 mm) barbed T drain fitting located on front of cooler.
- Designed to accommodate all types of beer kegs.
- Comes standard with a two-way tapper manifold.
- Listed under NSF-7 for the storage and/or display of packaged or bottled product.

### ELECTRICAL

- Unit completely pre-wired at factory and ready for final connection to a 115/60/1 phase, 15 amp dedicated outlet. Cord and plug set included.



115/60/1  
NEMA-5-15R

### OPTIONAL FEATURES/ACCESSORIES

Upcharge and lead times may apply.

- 230 - 240V / 50 Hz.
- 6" (153 mm) standard legs.
- 6" (153 mm) seismic/flanged legs.
- 2 1/2" (64 mm) diameter castors.
- 4" (102 mm) diameter castors.
- Double headed draft column.
- Triple headed draft column.
- Three-way tapper manifold.
- Draft cap.

## PLAN VIEW

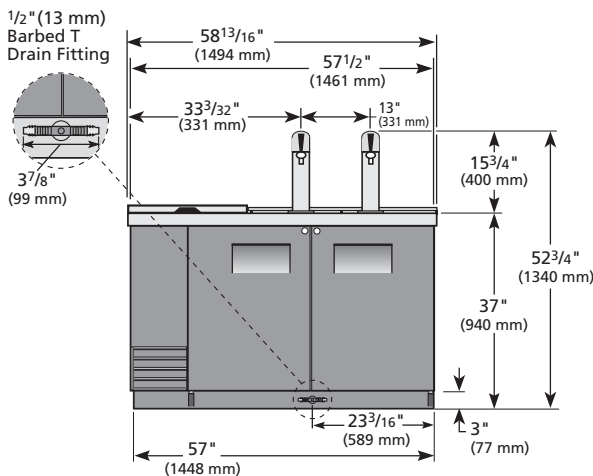

ELEVATION

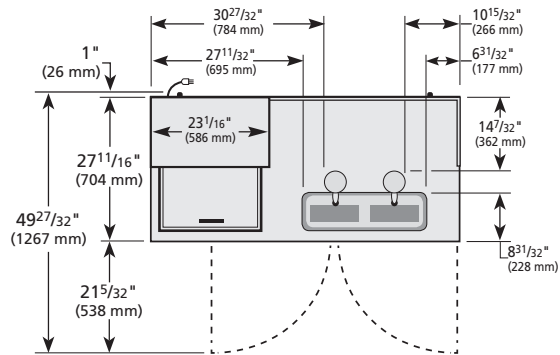

PLAN VIEW

### WARRANTY\*

Three year warranty on all parts and labor and an additional 2 year warranty on compressor. (U.S.A. only)

METRIC DIMENSIONS ROUNDED UP TO THE NEAREST WHOLE MILLIMETER

SPECIFICATIONS SUBJECT TO CHANGE WITHOUT NOTICE



Model	Elevation	Right	Plan	3D	Back
TDD-2CT	TFSY02E	TFSY02S	TFSY02P	TFSY023	

\*RESIDENTIAL APPLICATIONS: TRUE assumes no liability for parts or labor coverage for component failure or other damages resulting from installation in non-commercial or residential applications.

## TRUE FOOD SERVICE EQUIPMENT