



TRUE EUROPE

Field's End Road, Goldthorpe, Nr. Rotherham, South Yorkshire S63 9EU, UK
 www.truemfg.com • Tel +44 01709 888 080 • Fax +44 01709 880 838
 Free Phone 0 800 783 2049 • Free Phone to U.S. 0 800 894 928



natural refrigerant.

2/16

Model:
TFP-32-12M-D-2-HC

Food Prep Table:

Drawered Food Prep Unit with Hydrocarbon Refrigerant



TFP-32-12M-D-2-HC

- ▶ True's food prep units are designed with enduring quality that protects your long term investment.
- ▶ Factory engineered, self-contained, capillary tube system using environmentally friendly R290 hydro carbon refrigerant that has zero (0) ozone depletion potential (ODP), & three (3) global warming potential (GWP).
- ▶ Energy saving, environmentally friendly, exclusive forced-air refrigeration system holds 33°F to 41°F (.5°C to 5°C).
- ▶ All stainless steel front, top and ends. Matching aluminum finished back.
- ▶ Stainless steel, patented, foam insulated lid and hood keep pan temperatures colder, lock in freshness and minimize condensation. Removable for easy cleaning.
- ▶ Interior - attractive, NSF approved, clear coated aluminum liner. Stainless steel floor with coved corners.
- ▶ 8" (204 mm) deep, ½" (13 mm) thick, full length removable cutting board included. Sanitary, high density, NSF approved white polyethylene provides tough preparation surface.
- ▶ Each drawer accommodates Two (2) full size 12"L x 20"W x 6"D (305 mm x 508 mm x 153 mm) food pan (sold separately).
- ▶ Heavy-duty stainless steel drawer slides and rollers.
- ▶ Foamed-in-place using a high density, polyurethane insulation that has zero ozone depletion potential (ODP) and zero global warming potential (GWP).

PLAN VIEW

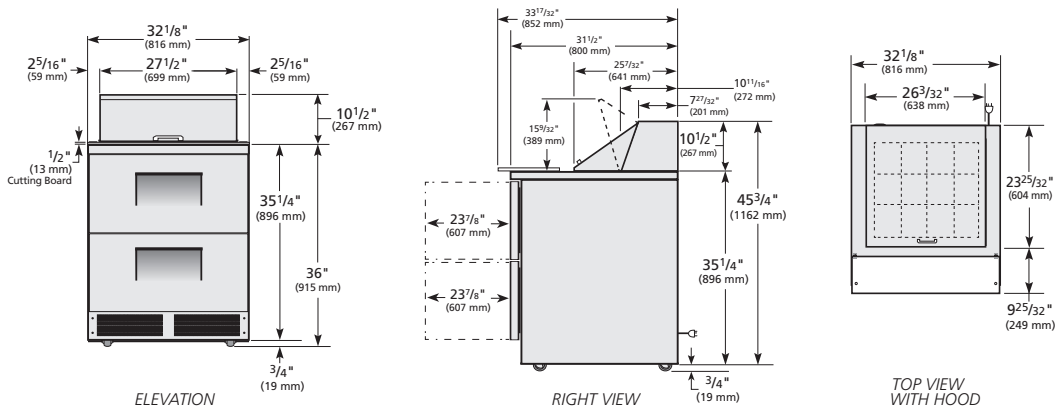

ROUGH-IN DATA

Specifications subject to change without notice.
 Chart dimensions rounded up to the next whole millimeter (inches rounded up to the next 1/8").

Model	Drawers	Cabinet Dimensions (mm)			HP	Voltage	Amps	NEMA Config.	Cord Length (total m)	Crated Weight (kg)
		W	D	H						
TFP-32-12M-D-2-HC	2	816	801	1181	1/4	230-240/50/1	1.9	▲	2.13	148

† Depth does not include 51 mm for cutting board.

▲ Plug type varies by country.