



TRUE EUROPE

Field's End Road, Goldthorpe, Nr. Rotherham, South Yorkshire S63 9EU, UK  
 www.truemfg.com • Tel +44 01709 888 080 • Fax +44 01709 880 838  
 Free Phone 0 800 783 2049 • Free Phone to U.S. 0 800 894 928



2/16

Model:  
**TPP-67D-4-HC**

**Food Prep Table:**  
*Drawered Pizza Prep Table with Hydrocarbon Refrigerant*



## TPP-67D-4-HC

- ▶ True's pizza prep tables are designed with enduring quality that protects your long term investment.
- ▶ Factory engineered, self-contained, capillary tube system using environmentally friendly R290 hydro carbon refrigerant that has zero (0) ozone depletion potential (ODP), & three (3) global warming potential (GWP).
- ▶ High capacity, factory balanced environmentally friendly forced-air refrigeration system holds 33°F to 41°F (.5°C to 5°C).
- ▶ Complies with and listed under ANSI/ NSF-7.
- ▶ All stainless steel front, top and ends. Matching aluminum finished back.
- ▶ Stainless steel, patented, foam insulated flat lids keep pan temperatures colder, lock in freshness, and minimize condensation.
- ▶ Interior - attractive, NSF approved, clear coated aluminum liner. Stainless steel floor with coved corners.
- ▶ Extra-deep 19 1/2" (496 mm) full length removable cutting board included. Sanitary, high density, NSF approved white polyethylene provides tough preparation surface.
- ▶ Each drawer accommodates two (2) full size 12"L x 20"W x 8"D (305 mm x 508 mm x 204 mm) pans (sold separately).
- ▶ Foamed-in-place using a high density, polyurethane insulation that has zero ozone depletion potential (ODP) and zero global warming potential (GWP).

### PLAN VIEW

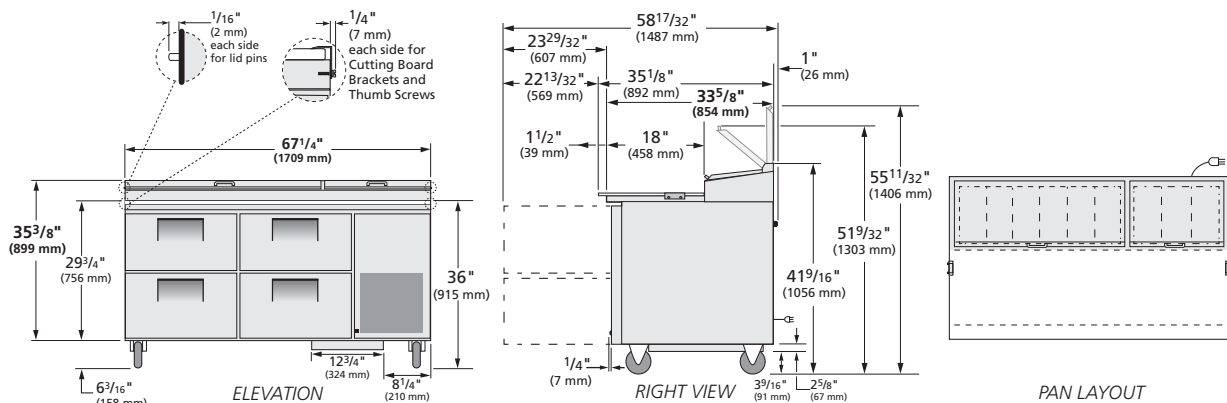

### ROUGH-IN DATA

Specifications subject to change without notice.  
 Chart dimensions rounded up to the next whole millimeter (inches rounded up to the next 1/8").

Model	Drawers	Cabinet Dimensions (mm)			HP	Voltage	Amps	NEMA Config.	Cord Length (total m)	Crated Weight (kg)
		W**	D†	H						
TPP-67D-4-HC	4	1709	854	1056	1/2	230-240/50/1	3.4	▲	2.13	188

\*\* Width does not include 7 mm each side for cutting board brackets and thumb screws.  
 † Depth does not include 26 mm for rear bumpers and 77 mm for cutting board.

▲ Plug type varies by country.