



TRUE EUROPE

UK OFFICE: Field's End Road, Goldthorpe, Nr. Rotherham, South Yorkshire S63 9EU, UK  
 Tel +44 01709 888 080 • Fax +44 01709 880 838 • Free Phone 0 800 783 2049  
 Free Phone to U.S. 0 800 894 928 • EU OFFICE: Hauptstr. 269 • 79650 Schopfheim • Germany  
 Tel +49 07622 6883 0 • Fax +49 07622 6883 499 • www.truemfg.com



8/16

Model:  
**TUC-24F-HC**

**Undercounter:**  
*Solid Door Freezer with Hydrocarbon Refrigerant*



### TUC-24F-HC

- ▶ True's undercounter units are designed with enduring quality that protects your long term investment.
- ▶ Designed using the highest quality materials and components to provide the user with colder product temperatures, lower utility costs, exceptional food safety and the best value in today's food service marketplace.
- ▶ Factory engineered, self-contained, capillary tube system using environmentally friendly R290 hydro carbon refrigerant that has zero (0) ozone depletion potential (ODP), & three (3) global warming potential (GWP).
- ▶ All stainless steel front, top and ends. Matching aluminum finished back.
- ▶ Interior - attractive, NSF approved, clear coated aluminum liner. Stainless steel floor with covered corners.
- ▶ Heavy duty PVC coated gray wire shelves.
- ▶ Automatic defrost system time-initiated, time-terminated.
- ▶ Foamed-in-place using a high density, polyurethane insulation that has zero ozone depletion potential (ODP) and zero global warming potential (GWP).

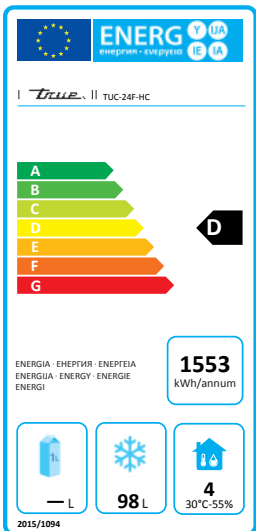

### PLAN VIEW

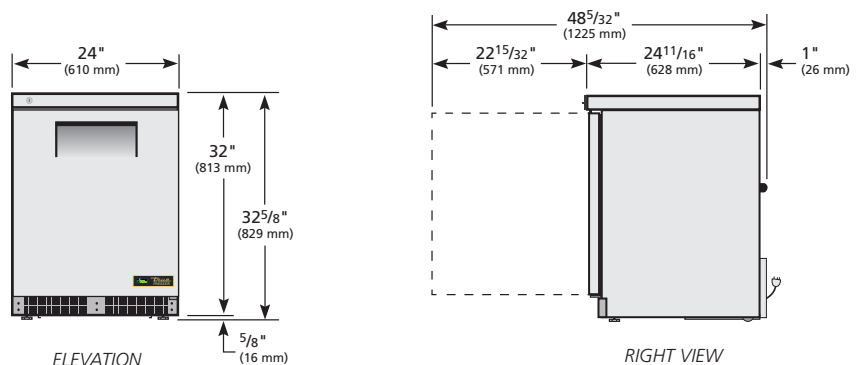

### ROUGH-IN DATA

Specifications subject to change without notice.  
 Chart dimensions rounded up to the next whole millimeter (inches rounded up to the next 1/8").

Model	Model Type	Doors	Shelves	Cabinet Dimensions (mm)			Net Volume (litres)	EEC	EEI	24 hr/ Energy Consumption (kWh)	Annual Energy Consumption (kWh)	Crated Weight (kg)
				L	D†	H						
TUC-24F-HC	Counter Frozen	1	2	610	629	829	98	D	53	4.256	1553	75

† Depth does not include 26 mm for rear bumpers.