



TRUE EUROPE

UK OFFICE: Field's End Road, Goldthorpe, Nr. Rotherham, South Yorkshire S63 9EU, UK
 Tel +44 01709 888 080 • Fax +44 01709 880 838 • Free Phone 0 800 783 2049
 Free Phone to U.S. 0 800 894 928 • EU OFFICE: Hauptstr. 269 • 79650 Schopfheim • Germany
 Tel +49 07622 6883 0 • Fax +49 07622 6883 499 • www.truefmfg.com



9/16

Model:
TWT-27F-D-2-HC

Worktop:
Drawered Freezer with Hydrocarbon Refrigerant



TWT-27F-D-2-HC

- ▶ True's worktop units are designed with enduring quality that protects your long term investment.
- ▶ Designed using the highest quality materials and components to provide the user with colder product temperatures, lower utility costs, exceptional food safety and the best value in today's food service marketplace.
- ▶ Factory engineered, self-contained, capillary tube system using environmentally friendly R290 hydro carbon refrigerant that has zero (0) ozone depletion potential (ODP), & three (3) global warming potential (GWP).
- ▶ Oversized, environmentally friendly forced-air refrigeration system holds -10°F (-23.3°C). Ideal for both frozen foods and ice cream.
- ▶ All stainless steel front, top and ends. Matching aluminum finished back. Top and backsplash are one piece formed construction. Bacteria and food particles cannot be trapped underneath as with other two-piece worktop units.
- ▶ Interior - attractive, NSF approved, clear coated aluminum liner. Stainless steel floor with coved corners.
- ▶ Each drawer accommodates one (1) full size 12"L x 20"W x 6"D (305 mm x 508 mm x 153 mm) food pan (sold separately).
- ▶ Foamed-in-place using a high density, polyurethane insulation that has zero ozone depletion potential (ODP) and zero global warming potential (GWP).

PLAN VIEW

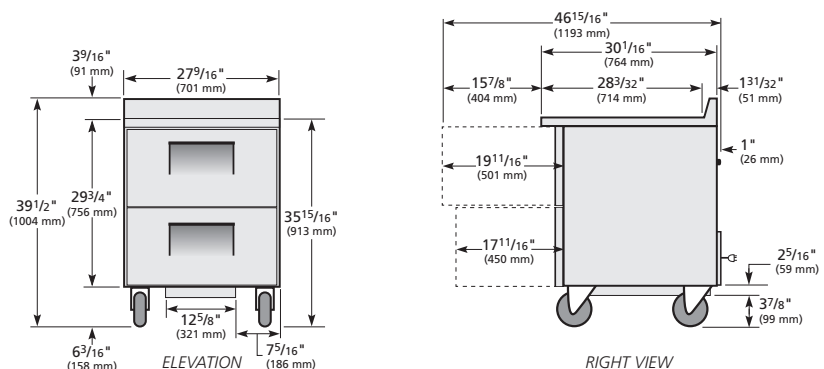

ROUGH-IN DATA

Specifications subject to change without notice. Chart dimensions rounded up to the next whole millimeter (inches rounded up to the next 1/8").

Model	Model Type	Drawers	Cabinet Dimensions (mm)			Net Volume (litres)	EEC	EEI	24 hr/ Energy Consumption (kWh)	Annual Energy Consumption (kWh)	Crated Weight (kg)
			L	D	H						
TWT-27F-D-2-HC	Counter Frozen	2	702	766	1007	40	D	55.5	3.975	1451	105

† Depth does not include 26 mm for rear bumpers.