

# AyrKing Corporation

## Breader/Blender/Sifter



AyrKing offers a side by side manual breadng workstation with integrated automatic Blender/Sifter machines. Rotary brush sifter operates without detrimental vibration or agitation. Spirally configured nylon bristles form an auger to eject unwanted dough balls to a waste container. Ingredients are fully blended as brush tumbles breadng media before it exits through sifter screen. Unique process prevents dough ball grinding, eliminates usual sifting noise, & blends ingredients as it ejects waste.

Photo of BBS-U-8132



### INCLUDED ACCESSORIES

- (2) B101 Red plastic lug plug
- (2) B304 White plastic dough ball pan
- (2) B122 Round dip basket, stainless steel wire
- (2) B123 Round dip pot, stainless steel
- B302 White plastic breadng lug with hole
- B303 White plastic breadng lug without hole
- B325 White plastic lug cover
- B302G Gray plastic breadng lug with hole
- B303G Gray plastic breadng lug without hole
- B325G Gray plastic lug cover
- B241 Swivel casters, four locking 5" (13mm)

### OPTIONAL ACCESSORIES

- B126 Feathering basket, stainless steel wire
- B124 Round dip pot lid, stainless steel

### ADVANTAGES

- Sift and blend 30 lbs (14 kg) of breadng in 60 seconds in each sifter!
- Rotary auger brush blends, sifts, and ejects dough balls simultaneously
- Blending brush action prevents ingredient segregation, unlike vibrating or agitating systems
- Quiet, vibration-free operation creates results, not disturbances
- Sixty second timed cycle frees labor and saves energy
- Raised s/s lip around sifter opening prevents tabletop spills from contaminating sifted breadng
- Fully enclosed sifter with only four internal parts, reduces dust and allows quick and easy cleaning
- Direct drive, steel geared motor & solid stainless steel fabrication provide lasting performance
- Gray and white colored breadng lugs help distinguish breadngs
- Integral rear shelf fits three full size bun pan (18"x26") and includes lip to hold bun pans in place

### MODEL

BBS-U-8132      81"L by 32"W table on casters with integrated rear shelf and backsplash

AyrKing Corporation  
2013 Cobalt Drive  
Louisville, KY 40299-2417

Telephone 502-266-6270  
Facsimile 502-266-6274  
www.ayrking.com

# AyrKing Corporation

# Breader/Blender/Sifter

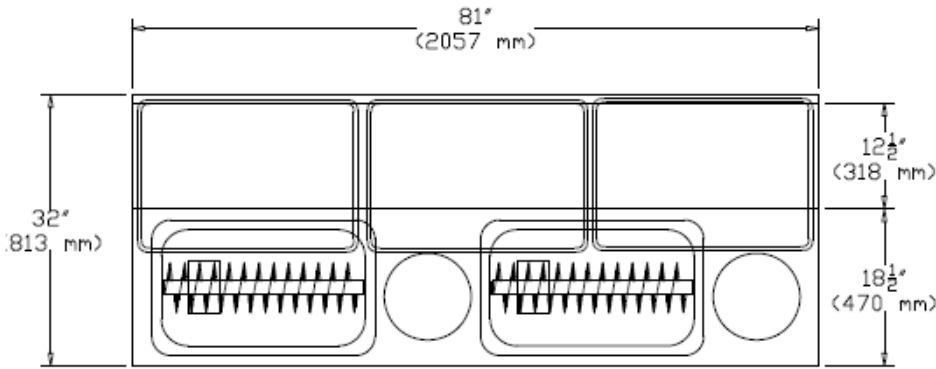

PLAN VIEW

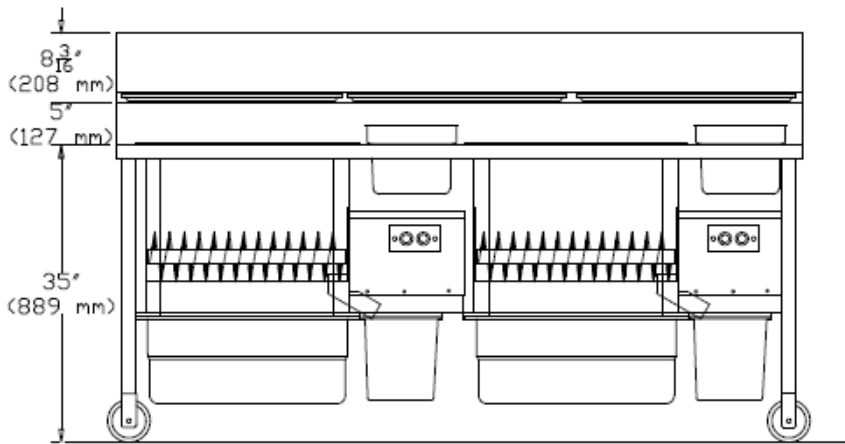

FRONT ELEVATION

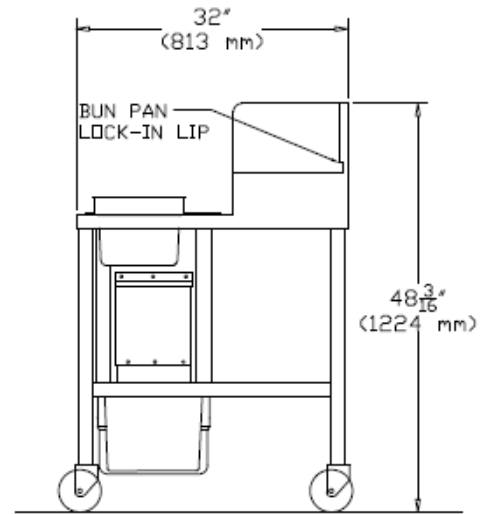

RIGHT END VIEW

### CRATED MEASUREMENTS

MODEL	LENGTH	WIDTH	HEIGHT	WEIGHT	UNCRATED
BBS-U-8132	86" (2184mm)	37" (940mm)	62" (1575mm)	400 lb (181kg)	315 lb (143kg)

### ELECTRICAL

Timed control board automatically senses voltage & operates at either:

115V, 50/60Hz, 1 phase, 1.6 AMP, 184W per sifter

230V, 50/60Hz, 1 phase, 0.9 AMP, 207W per sifter

Each sifter includes universal male three prong, recessed AC receptacle

(IEC 320 C13) mating to an 8 foot (2438mm) cord with NEMA 5-15P male three prong plug

### WARRANTY

One Year Parts

Ninety Days Labor

No Travel Time

Specifications subject to change without notice. Version 09/11

AyrKing Corporation  
2013 Cobalt Drive  
Louisville, KY 40299-2417

Telephone 502-266-6270  
Facsimile 502-266-6274  
www.ayrking.com