

# Combi steamer

Project \_\_\_\_\_  
 Item \_\_\_\_\_  
 Quantity \_\_\_\_\_  
 FCSI section \_\_\_\_\_  
 Approval \_\_\_\_\_  
 Date \_\_\_\_\_

## Model

Convotherm 4 easyDial

- easyDial
- 20 Shelves GN 1/1
- Electric
- Injection/Spritzer
- Disappearing door



## Key features

- ACS+ operating modes: Steam, Combi-steam, Convection
- ACS+ Extra Functions:
  - Crisp&Tasty – 5 moisture-removal settings
  - BakePro – 5 levels of traditional baking
  - HumidityPro – 5 humidity settings
  - Controllable fan – 5 speed settings
- easyDial: all functions can be set on one operating level
- Semi-automatic cleaning system
- HygienicCare
- USB port integrated in the control panel
- TriColor indicator ring – indicates the current operating status
- Steam generated by injecting water into the cooking chamber
- Disappearing door: more space and greater safety at work (optionally available for an extra charge)

## Standard features

- ACS+ (Advanced Closed System +) operating modes:
  - Steam (30-130°C) with guaranteed steam saturation
  - Combi-steam (30-250°C) with automatic humidity adjustment
  - Convection (30-250°C) with optimized heat transfer
- HygienicCare – food safety thanks to antibacterial surfaces:
  - easyDial control panel
  - Door handle and recoil hand shower
- easyDial user interface:
  - Central control unit, Convotherm-Dial (C-Dial)
  - Digital display
  - Regenerating function – regenerates products to their peak level
  - 99 cooking profiles each with up to 9 steps
- Multi-point core temperature probe
- Door handle with safety latch
- Built-in preheat bridge
- Data storage for HACCP and pasteurization figures
- Preheat and cool down function

## Options

- ConvoClean fully automatic cleaning system – including optional single-measure dispensing
- Steam and vapour removal – built-in condensation module (on request)
- Marine version (see separate datasheet)
- Prison version
- Ethernet interface (LAN)
- Available in various voltages
- Sous-vide probe, external connection
- Core temperature probe, external connection

## Accessories

- ConvoLink – HACCP and cooking profile management PC software
- ConvoVent 4 condensation hood with grease filter
- ConvoVent 4+ condensation hood with grease and odour filter
- Signal tower – external operating-state indicator
- Banquet system (optionally as a package or individually): Plate loading trolley, loading trolley, thermal cover
- Care products for the ConvoClean fully automatic cleaning system (multiple and single-measure dispensing) and for semi-automatic oven cleaning



**Front view**

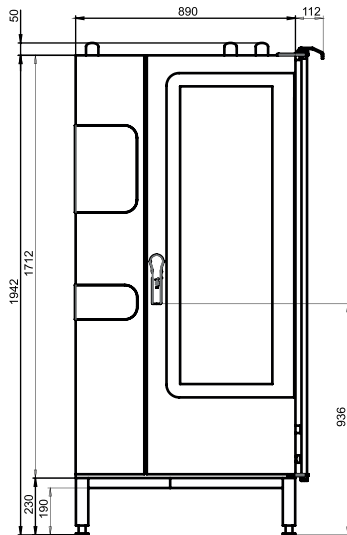

**Connection positions**

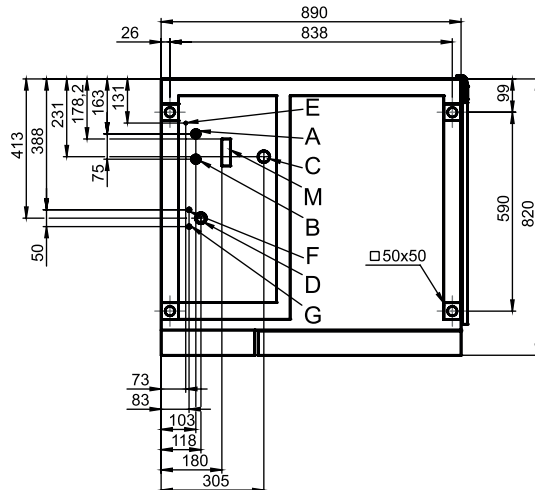

- A** Water connection (for water injection)
- B** Water connection (for cleaning, recoil hand shower)
- C** Drain connection DN 50
- D** Electrical connection
- E** Equipotential bonding
- F** Rinse-aid connection
- G** Cleaning-agent connection
- H** Air vent Ø 50 mm
- I** Ventilation port Ø 50 mm
- M** Safety overflow 80 mm x 25 mm

**View from above with wall clearances**

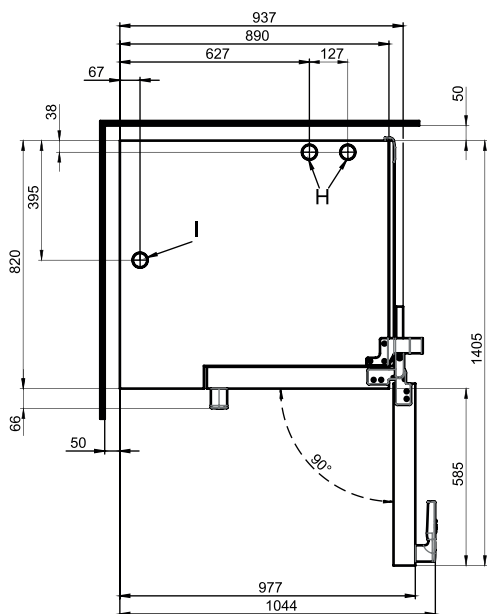

**Dimensions and weights**

**Dimensions including packaging**

Width x Height x Depth 1165 x 2150 x 970 mm

**Weight**

Empty weight without options\* / accessories 270 kg

Weight of packaging 40 kg

**Safety clearances\*\***

Rear 50 mm

Right-hand side (disappearing door pushed back) 160 mm

Left (larger gap recommended for servicing) 50 mm

Top\*\*\* 500 mm

\* Weight of options 15 kg max.

\*\* Minimum distance from heat sources: 500 mm.

\*\*\* Depends on type of air ventilation system and nature of ceiling.

**Installation instructions**

Absolute tilt of unit in operation\* max. 2° (3.5%)

\* Adjustable feet included as standard.

### Loading capacity

#### Max. number of food containers

GN 1/1*	20
600 x 400** baking tray	17
Plates max. Ø 32 cm, Ring spacing 66 mm**	61
Plates max. Ø 32 cm, Ring spacing 79 mm**	50

#### Maximum loading weight

GN 1/1 / 600 x 400	
Per combi steamer	100 kg
Per shelf level	15 kg

\* Matching loading trolley included as standard.

\*\* Matching loading trolley available as an accessory.

### Electrical supply

#### 3N~ 400V 50/60Hz\*

Rated power consumption	38.9 kW
Rated current	56.2 A
Fuse rating	63 A
RCD (GFCI), frequency converter (single phase)	Type A (recommended), type B/F (optional)
Recommended conductor cross-section	5G16

#### 3~ 230 V 50/60Hz\*

Rated power consumption	38.2 kW
Rated current	96.0 A
Fuse rating	100 A
RCD (GFCI), frequency converter (single phase)	Type A (recommended), type B/F (optional)
Recommended conductor cross-section	4G35

#### 3~ 200 V 50/60Hz\*

Rated power consumption	38.2 kW
Rated current	110.4 A
Fuse rating	125 A
RCD (GFCI), frequency converter (single phase)	Type A (recommended), type B/F (optional)
Recommended conductor cross-section	4G50

#### 3~ 400 V 50/60Hz\*

Rated power consumption	38.9 kW
Rated current	56.2 A
Fuse rating	63 A
RCD (GFCI), three-phase frequency converter	Type B/F (recommended)
Recommended conductor cross-section	5G16

\* Connection to energy optimization system included as standard.

### Water connection

#### Water supply

Water supply	2 x G 3/4" permanent connection, optionally including connecting pipe (min. DN13 / 1/2")
Flow pressure	150 - 600 kPa (1.5 - 6 bar)

#### Appliance drain

Drain version	Permanent connection (recommended) or open tank or channel/gully
Type	DN50 (min. internal Ø: 46 mm)
Slope for waste-water pipe	min. 3.5% (2°)

### Water quality

#### Water-supply connection A\* for water injection

General requirements	Drinking water, typically soft water (install water treatment system if necessary)
Total hardness	4 - 7 °dh / 70 - 125 ppm / 7 - 13 °TH / 5 - 9 °e

#### Water-supply connection B\* for cleaning, recoil hand shower

General requirements	Drinking water, typically hard water
Total hardness	4 - 20 °dh / 70 - 360 ppm / 7 - 35 °TH / 5 - 25 °e

#### Water-supply connections A, B\*

pH value	6.5 - 8.5
Cl <sup>-</sup> (chloride)	max. 60 mg/l
Cl <sub>2</sub> (free chlorine)	max. 0.2 mg/l
SO <sub>4</sub> <sup>2-</sup> (sulphate)	max. 150 mg/l
Fe (iron)	max. 0.1 mg/l
Temperature	max. 40 °C
Electrical conductivity	min. 20 µS/cm

\* See diagram of connection positions, page 2.

### Water consumption

#### Water-supply connection A\*

Ø Consumption for cooking	8.1 l/h
Max. consumption	0.6 l/min

#### Water-supply connections A, B

Ø Consumption for cooking**	12.2 l/h
Max. water flow rate	15 l/min

\* Values for selecting the capacity of the water treatment system.

\*\* Including water used for cooling the wastewater.

PLEASE NOTE: See diagram of connection positions, page 2.

## Emissions

<b>Dissipated heat</b>	
Latent heat	6900 kJ/h / 1.92 kW
Sensible heat	8900 kJ/h / 2.47 kW
<b>Waste water temperature</b>	
	max. 80 °C
<b>Noise during operation</b>	
	max. 70 dBA

## ACCESSORIES

(Please refer to the Accessories brochure for detailed information)

### Condensation hood ConvoVent 4\*

<b>Electrical supply</b>	
Rated voltage	1N~ 200-240V 50/60Hz
Rated power consumption	260 W
Rated current	1.9 A
Fuse rating	2.5 A
<b>Dimensions excluding packaging</b>	
Width x Height x Depth	892 x 240 x 1086 mm
Weight excluding packaging	67 kg
<b>Safety clearance above**</b>	
	500 mm

\* Condensation hoods specially designed for stacking kits are available.

\*\* Depends on type of air ventilation system and nature of ceiling.

### Condensation hood ConvoVent 4+\*

<b>Electrical supply</b>	
Rated voltage	1N~ 200-240V 50/60Hz
Rated power consumption	260 W
Rated current	1.9 A
Fuse rating	2.5 A
<b>Dimensions excluding packaging</b>	
Width x Height x Depth	892 x 373 x 1086 mm
Weight excluding packaging	86 kg
<b>Safety clearance above**</b>	
	500 mm

\* Condensation hoods specially designed for stacking kits are available.

\*\* Depends on type of air ventilation system and nature of ceiling.

**Please observe the following points:**

- This document is to be used solely for planning purposes.
- Please refer to the Installation Manual for further technical data and guidance on installation and positioning.

9758212\_03 ENG\_GBR 08/15. © 2015 Manitowoc. Continuous improvements to the product may mean changes to the specification are made without explicit mention.