



Project _____
 Item _____
 Quantity _____
 CSI Section 11400 _____
 Approval _____
 Date _____

Sandwich Holding Station

Sandwich Holding Station

Models

SHS18

SHS22



SHS Standard Features

- Open-top, no lamps or bulbs needed
- Controlled heat, prevents cooking and drying
- Heated air ensures even heat distribution
- Simple to operate -- pass-through design
- 6 ft. (1.8 m) power cord with twist lock or pin-n-sleeve
- Stainless steel construction

Specifications

Frymaster's Sandwich Holding Station is a specially designed, heated holding unit that optimizes the hot holding of wrapped foods.

The plate and air temperatures are preset to keep food hot without drying or cooking. As hot air circulates over the open top, even heating is provided to all surfaces of the food.

Wrapped foods are placed on the Sandwich Holding Station, while the balance of the order is being assembled. Custom orders are delivered hot and fresh providing higher customer satisfaction and lower waste.

The SHS is constructed of stainless steel and features an aluminum anodized heated surface area. The heater plate temperature and air temperature are independently controlled. The digital controls on the unit allow the plate and air temperature set points to be adjusted and monitored independently.

Independent thermocouple jacks are provided for simple verification of the air and surface temperatures.



8700 Line Avenue
 Shreveport, LA 71106-6800
 USA

Tel: 318-865-1711
 Tel: 1-800-221-4583
 Fax: 318-868-5987
 E-mail: info@frymaster.com

www.frymaster.com
 Bulletin No. 818-0720
 Revised 8/1/13



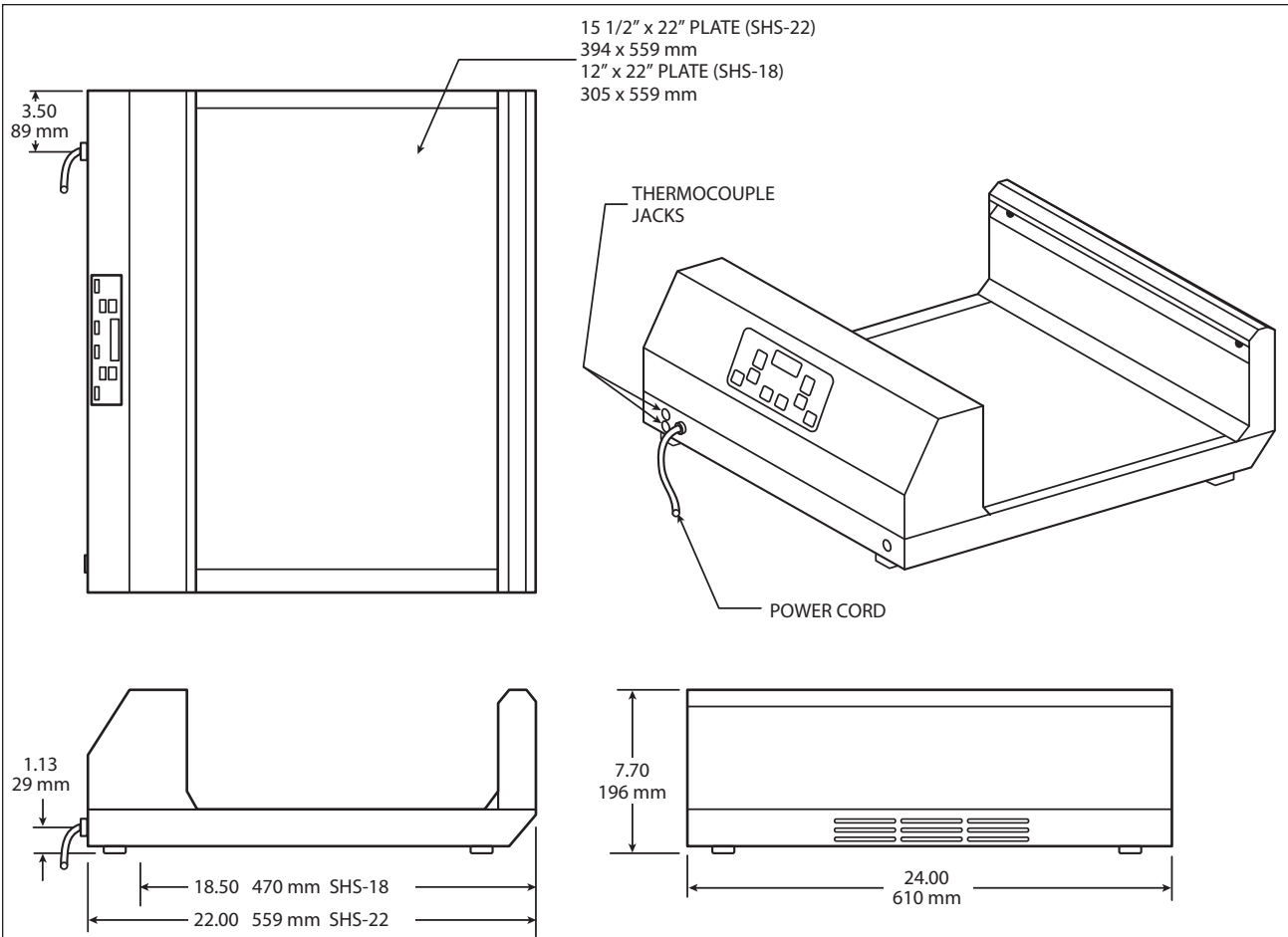

DIMENSIONS

MODEL NO.	LANDING AREA (cm)	DIMENSIONS (cm)			NET WEIGHT	APPROXIMATE SHIPPING DIMENSIONS						
		WIDTH	DEPTH	HEIGHT		WEIGHT	CLASS	CU. FT.	DIMENSIONS (cm)			
SHS18	12" x 22" (30.5 x 55.9)	24" (61.0)	18-1/2" (47.0)	7-3/4" (19.6)	35 lbs. (25 kg)	55 lbs. (25 kg)	85	4.66	W 28" (71.1)	D 24" (61.0)	H 12" (30.5)	
SHS22	15-1/2" x 22" (39.4 x 55.9)	24" (61.0)	22" (55.9)	7-3/4" (19.6)	44 lbs. (20 kg)	65 lbs. (30 kg)	85	5.06	28" (71.1)	26" (66.0)	12" (30.5)	

POWER REQUIREMENTS

BASIC DOMESTIC	VOLTAGE	1 PHASE	HZ	WATTS
	208V	12 A	60	2,500
	240V	10.5 A	60	2,520
BASIC EXPORT	VOLTAGE	1 PHASE	HZ	WATTS
	220V	10A	50	2,200
	230V	9.4 A	50	2,160
	240V	10.5 A	60	2,520
BASIC CE	VOLTAGE	1 PHASE	HZ	WATTS
	230V	9.4 A	50	2,160

NOTES:

- 6 ft. (1.8 m) cord with twist lock plug provided

Model # _____
CSI Section 11400

8700 Line Avenue
Shreveport, LA 71106-6800
USA

Tel: 318-865-1711
Tel: 1-800-221-4583
Fax: 318-868-5987
E-mail: info@frymaster.com

www.frymaster.com
Bulletin No. 818-0720
Revised 8/1/13
Litho in U.S.A. ©Frymaster

