

Indigo™ Series 322 Ice Cube Machine

Model: ID-0322A IY-0324A ID-0323W IY-0325W



Indigo Series i-322 Ice Machine on B-320 Bin

Designed for operators who know that ice is critical to their business, the Indigo™ Series ice machine's preventative diagnostics continually monitor itself for reliable ice production. Improvements in cleanability and programmability make your ice machine easy to own and less expensive to operate.

- **Space-Saving Design** – Up to 350 lbs. (159 kgs.) daily ice production and only 22" (55.88 cm) wide.
- **Intelligent Diagnostics** – provide 24 hour preventative maintenance and diagnostic feedback for trouble free operation.
- **Acoustical Ice Sensing Probe** – for reliable operation in challenging water conditions.
- **EasyRead Display** – communicates operating status, cleaning reminders, and asset information through a blue illuminated display.
- **Programmable Ice Production** – by On/Off Time, Ice Volume or Bin Level (with accessory bin level control) further improves energy efficiency and savings.
- **Easy to Clean Foodzone** – Hinged front door swings out for easy access. Removable water-trough, distribution tube, curtain, and sensing probes for fast and efficient cleaning. Select components made with AlphaSan® antimicrobial.
- **DuraTech™ Exterior** – provides superior corrosion resistance. Stainless finish with innovative clear-coat resists fingerprints and dirt.
- Available **LuminIce™ Growth Inhibitor** controls the growth of bacteria and yeast within the foodzone.

Ice Machine Electric

115/60/1 standard.
(208-230/60/1 and 230/50/1 also available)

Minimum circuit ampacity:

Air-cooled: 11.5 1ph
Water-cooled: 10.7 1ph

Maximum fuse size:

Air-cooled: 15 amps
Water-cooled: 15 amps



Specifications

BTU Per Hour:

3,300 (average) 4,500 (peak)

Refrigerant:

R-404A CFC-free

Operating Limits:

- Ambient Temperature Range: 35° to 110°F (1.7° to 43.3°C)
Water Temperature Range: 35° to 90°F (1.7° to 32.2°C)
- Water Pressure Ice Maker Water In:
Min. 20 psi (137.9 kPa)
Max. 80 psi (551.1 kPa)

Ice Shape



Half Dice
3/8" x 1 1/8" x 7/8"
(.95 x 2.86 x 2.22 cm)



Dice
7/8" x 7/8" x 7/8"
(2.22 x 2.22 x 2.22 cm)





Indigo™ Series 322 Ice Cube Machine

i-322 on B-320 Storage Bin

- Ⓐ Electrical Entrance (2) Options
- Ⓑ 3/8" (0.95 cm) F.P.T. Water Condenser Inlet (water-cooled units)
- Ⓒ 1/2" (1.27 cm) F.P.T. Water Condenser Outlet (water-cooled units)
- Ⓓ 1/2" (1.27 cm) Auxillary Base Drain Socket
- Ⓔ 3/8" (0.95 cm) F.P.T. Ice Making Water Inlet
- Ⓕ 1/2" (1.27 cm) F.P.T. Ice Making Water Drain
- Ⓖ 3/4" (1.91 cm) Bin Drain

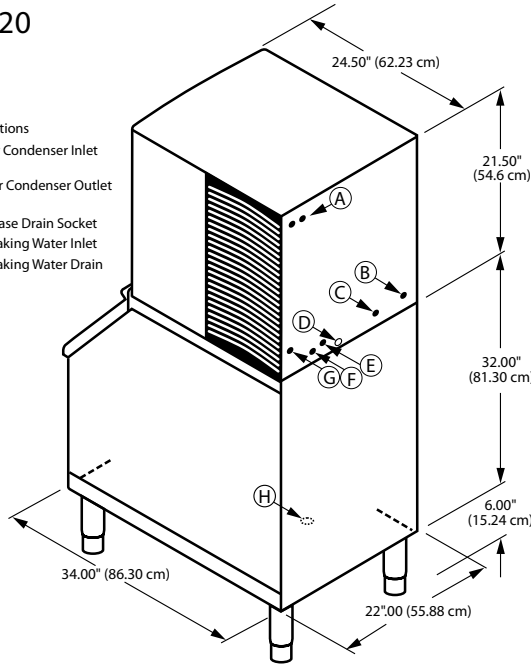

Installation Note
Minimum installation clearance:
Top/sides: 8" (20.32 cm);
Back is 5" (12.7 cm)

Space-Saving Designs



	i-322 B-320	i-322 B-420
Height	59.50" 151.13 cm	71.50" 194.31 cm
Width	22.00" 55.88 cm	22.00" 55.88 cm
Depth	34.00" 86.30 cm	34.00" 86.30 cm
Bin Storage	210 lbs. 95 kgs.	310 lbs. 141 kgs.

Height includes adjustable bin legs 6.00" to 8.00", (15.24 to 20.32 cm) set at 6.00" (15.24 cm).

Specifications

	Model	Ice Shape	Ice Production 24 Hours		Power Usage kWh/100 lbs. @90°Air/70°F	Water Usage/100 lbs. 45.4 kgs. of Ice		ENERGY STAR*
			70°Air/ 50°F Water	90°Air/ 70°F Water		Potable Water		
AIR-COOLED	ID-0322A	dice	335 lbs.	225 lbs.	7.49	23.9 Gal.	★	
			152 kgs.	102 kgs.		90.5 L		
AIR-COOLED	IY-0324A	half-dice	350 lbs.	230 lbs.	7.32	23.9 Gal.	★	
			159 kgs.	104 kgs.		90.5 L		
WATER-COOLED	ID-0323W	dice	330 lbs.	270 lbs.	6.19	23.9 Gal.	NA	
			150 kgs.	122 kgs.		90.5 L		
WATER-COOLED	IY-0325W	half-dice	350 lbs.	290 lbs.	5.94	23.9 Gal.	NA	
			159 kgs.	132 kgs.		90.5 L		

* Water-cooled Condenser Water Usage / 100 lbs. /45.4 kgs. Of Ice: 193 gal/731 L.
* Water-cooled models are excluded from ENERGY STAR qualification.

Order ice storage bin separately.

Accessories

LuminIce™ Growth Inhibitor
reduces yeast and bacteria growth for a cleaner ice machine.



Bin Level Control
Allows ice bin level to be automatically set. Built-in LED light illuminates bin.



Arctic Pure® Water Filters
Reduces sediment and chlorine odors for better tasting ice.



AuCS®
schedules and performs routine ice machine cleaning automatically.

